

## TYPE 630 PUR

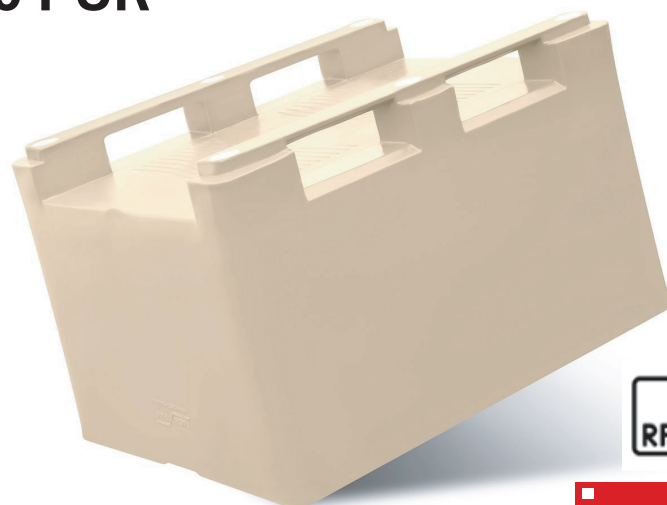

## PRODUCT SPECIFICATION SHEET



**PRODUCT ID** FP-630-1 PUR  
**MATERIAL** virgin PE-1A  
**INSULATION** polyurethane foam (PUR)

DIMENSIONS	Exterior	Interior maximum	Interior minimum
LENGTH	1200 mm	1160 mm	1131 mm
WIDTH	1000 mm	950 mm	926 mm
HEIGHT	785 mm	615 mm	600 mm

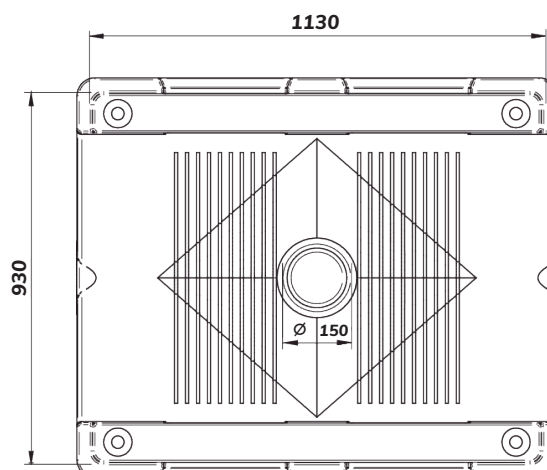
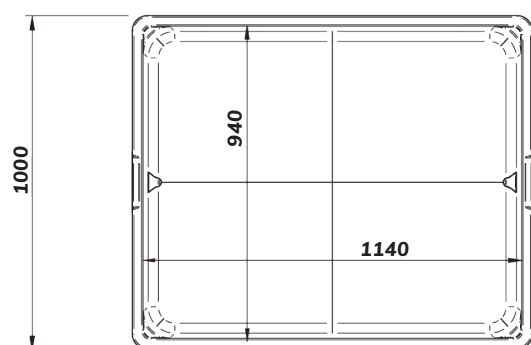
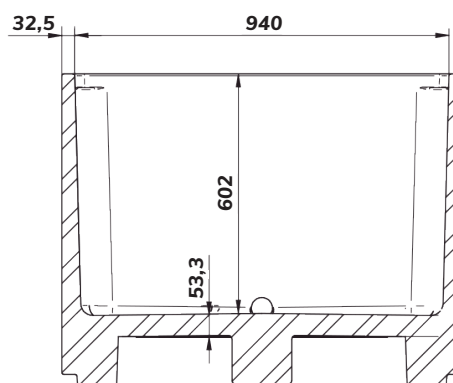
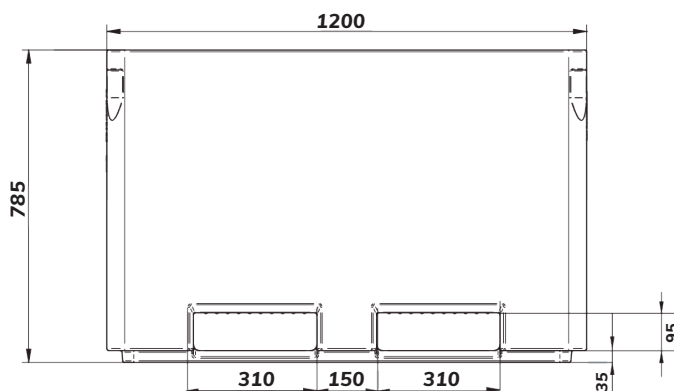

values  
in mm

<b>CAPACITY</b>	630 L
<b>WALL THICKNESS</b>	32,5 mm
<b>WEIGHT</b>	58 kg
<b>DRAIN HOLES</b>	0 - 1 - 2 / 2" BCS 56 x 4
<b>OPTION</b>	additional single central leg
<b>STACKABLE WITH</b>	type 630

internal shelves in the corners of the container enabling safe stacking

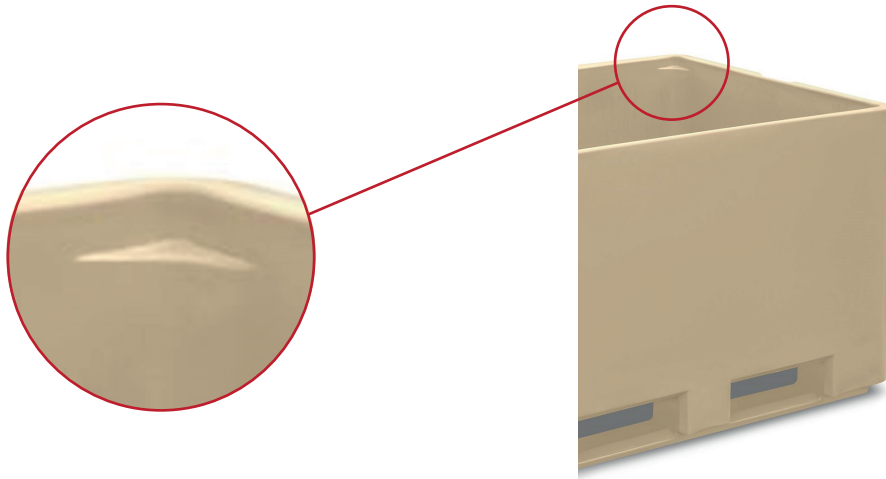

## CHARACTERISTIC

- smooth, solid and hygienic walls and bottom
- 2 runners
- up to 2 drainage holes with stoppers
- gravity floor and drips for easier drainage
- suitable for contact with perishable products
- strong and robust corners allowing safe operating with crane's lifting hooks
- stackable with or without lid
- rounded design for easy washing and cleaning
- pallet truck access from all 4 sides
- available in beige and blue colour, other colours upon request
- long lasting UV-protection

## IMPORTANT

- dimensional tolerance  $\pm 3\%$ , any changes and errors reserved.
- all technical data provided are guide values - they may vary because of specific applications and conditions, the information provided are based on the current knowledge and experience.
- the user is obliged to carry out its own tests and inspections before regular usage of the product.