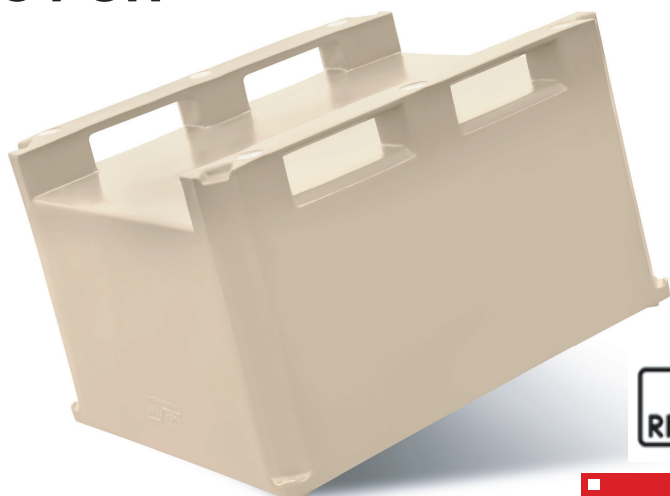

FACH**PAK**

Producer of the highest quality

insulated containers

TYPE 605 PUR**PRODUCT SPECIFICATION**

PRODUCT ID FP-605 PUR
MATERIAL virgin PE-1A
INSULATION polyurethane foam (PUR)

DIMENSIONS	Exterior	Interior maximum	Interior minimum
LENGTH	47.2 in	44.7 in	43.6 in
WIDTH	39.4 in	36.9 in	35.9 in
HEIGHT	29.9 in	22.4 in	21.9 in

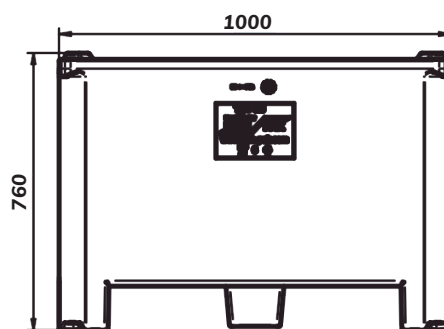
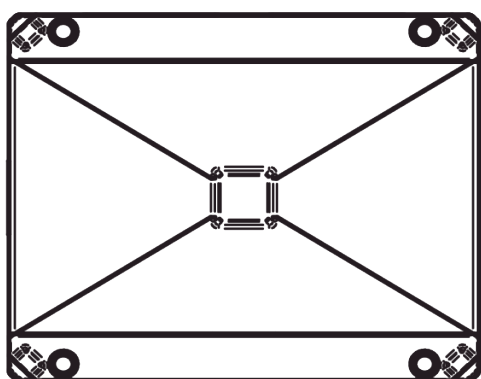
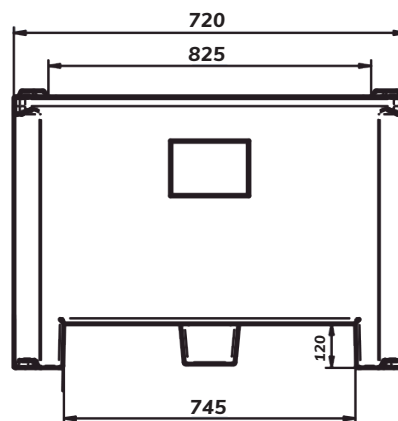
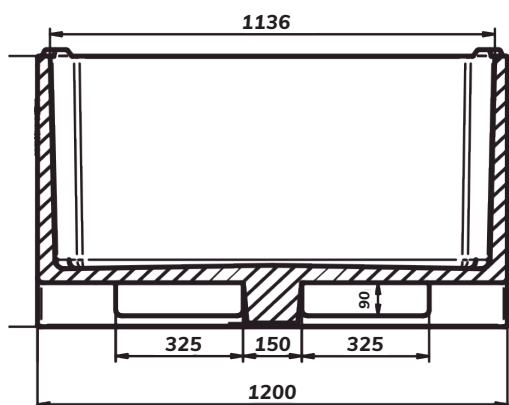
values
in mm

CAPACITY	159 gal
WALL THICKNESS	1.26 in
WEIGHT	108 lb
DRAIN HOLES	0 - 1 - 2 / 2" BCS 56 x 4
OPTION	additional single central leg
STACKABLE WITH	type 605 / Dolav

4 interlocking lugs to prevent slipping when stacked

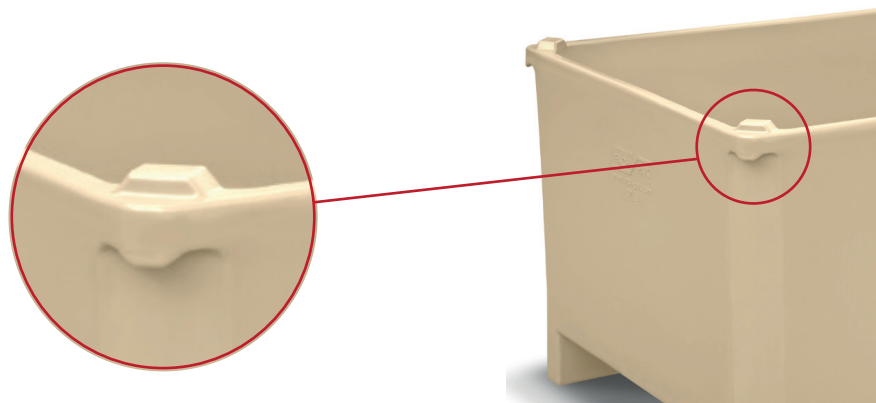

CHARACTERISTIC

- smooth, solid and hygienic walls and bottom
- 2 runners
- up to 2 drainage holes with stoppers
- gravity floor and drips for easier drainage
- suitable for contact with perishable products
- strong and robust corners allowing safe operating with crane's lifting hooks
- stackable with or without lid
- rounded design for easy washing and cleaning
- pallet truck access from all 4 sides
- available in beige and blue colour, other colours upon request
- long lasting UV-protection

IMPORTANT

- dimensional tolerance $\pm 3\%$, any changes and errors reserved.
- all technical data provided are guide values - they may vary because of specific applications and conditions, the information provided are based on the current knowledge and experience.
- the user is obliged to carry out its own tests and inspections before regular usage of the product.